

RACE?

Does it exist?



Andrew Rusnak

Is race a socially constructed idea or does it exist as a result of empirical evidence gathered from the scientific study of evolution and genetics?



1

Race is a modern idea. Ancient societies did not divide people according to physical differences, but according to religion, status, class, language.



2

Race has no genetic basis. Not one characteristic, trait, or gene distinguishes all members of one so-called race from all members of any other so-called race.



3

The early U.S. economy was built on slavery. A concept of race was invented to justify the denial of rights and freedoms others took for granted. A hierarchy, a power structure was born.

Source: PBS

http://www.pbs.org/race/001_WhatIsRace/001_00-home.htm

SCIENTIFIC AMERICAN

A 2003 Scientific American article referenced, “Many [scientific] studies have demonstrated that roughly 90 percent of human genetic variation occurs within a population living on a given continent, whereas 10 percent of the variation distinguishes continental populations.”

4

Most traits are inherited independently of one another. The genes for skin color have nothing to do with the genes for hair texture, eye shape, musical talent, blood type, athletic ability.



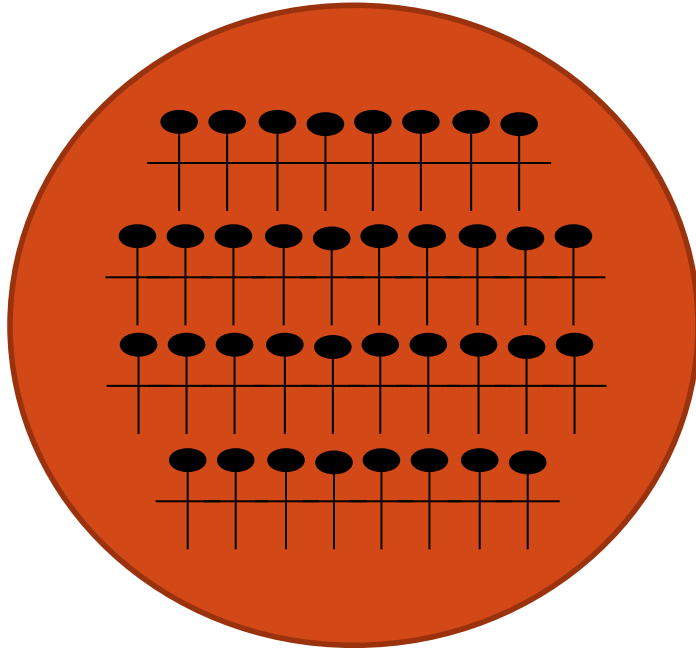

Continent 1

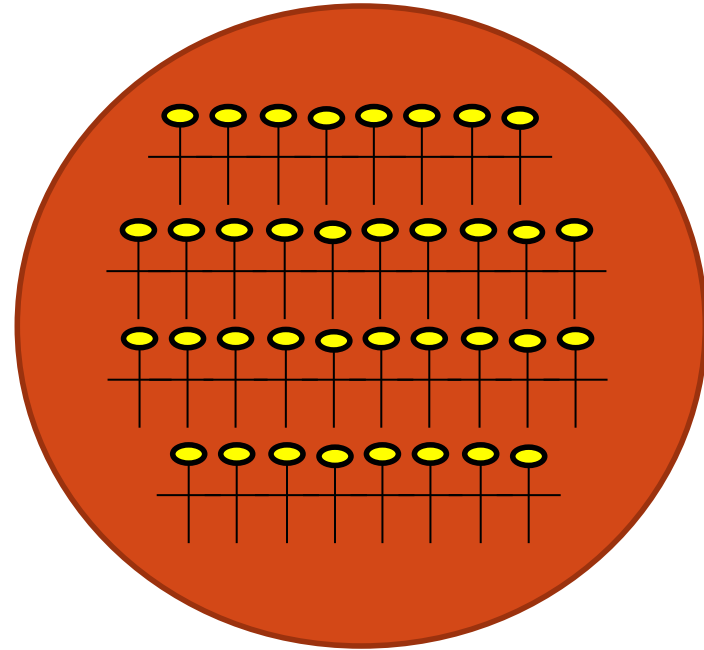

Continent 2



5

Most genetic variation is within not between races. Of the relatively small amount of total human variation, 90 percent exists within a local population no matter what their ethnicity – Korean, Pakistani, South African.  Can be more genetically diverse from  than from 

The term **Clines**: A biological term that examines the gradual change in certain characteristics [like skin color] exhibited by members of a series of adjacent populations or organisms of the same species.



Clines ...

“But if one were to walk up beside the Nile from Cairo, across the Tropic of Cancer to Khartoum in the Sudan and on to Nairobi, there would be no visible boundary [especially when it comes to skin color] between one people and another. The same thing would be true if one were to walk north from Cairo, through the Caucasus, and on up into Russia, eventually swinging west across the northern end of the Baltic Sea to Scandinavia.”

— *Dr. C. Loring Brace, University of Michigan*

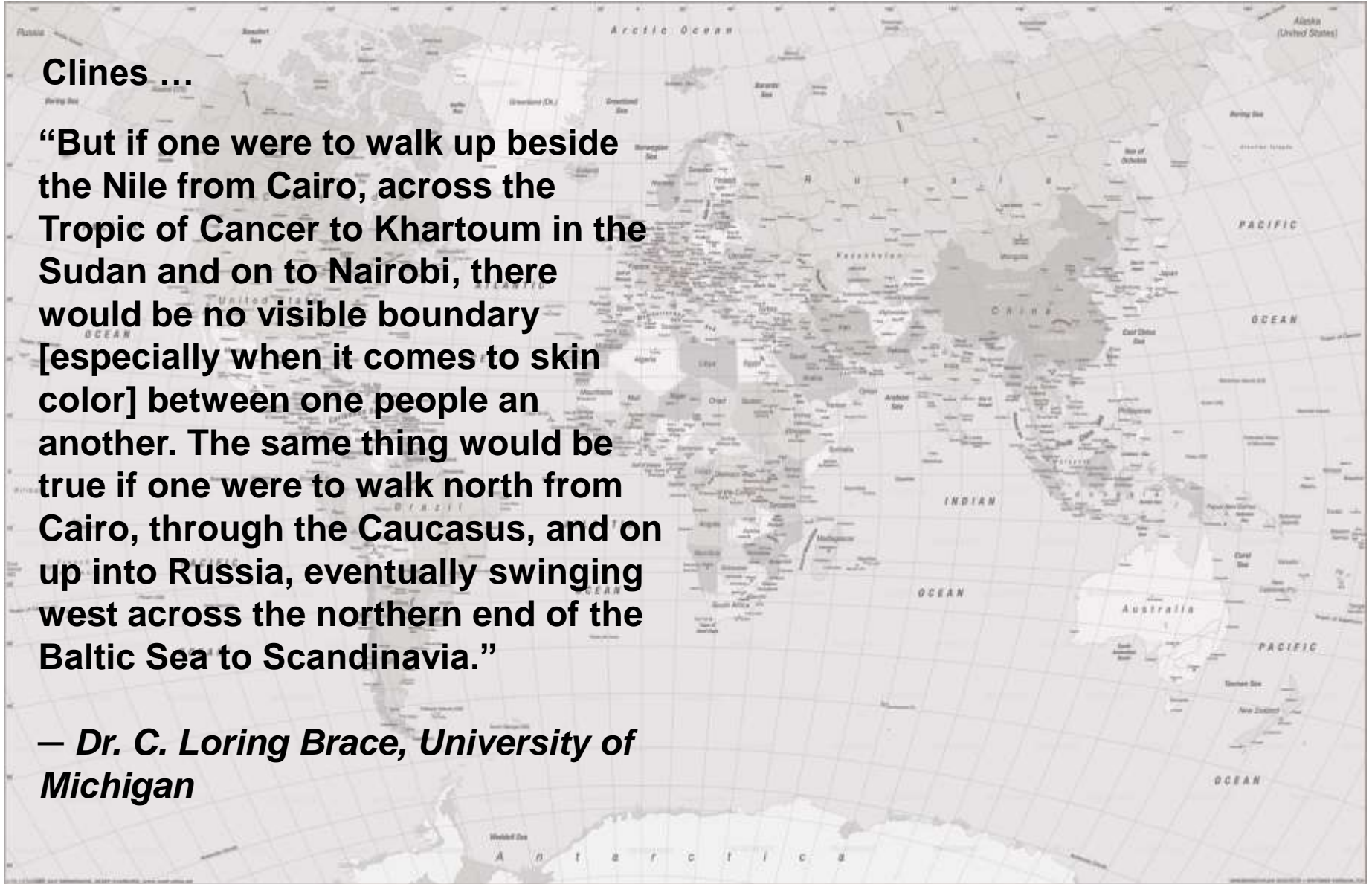

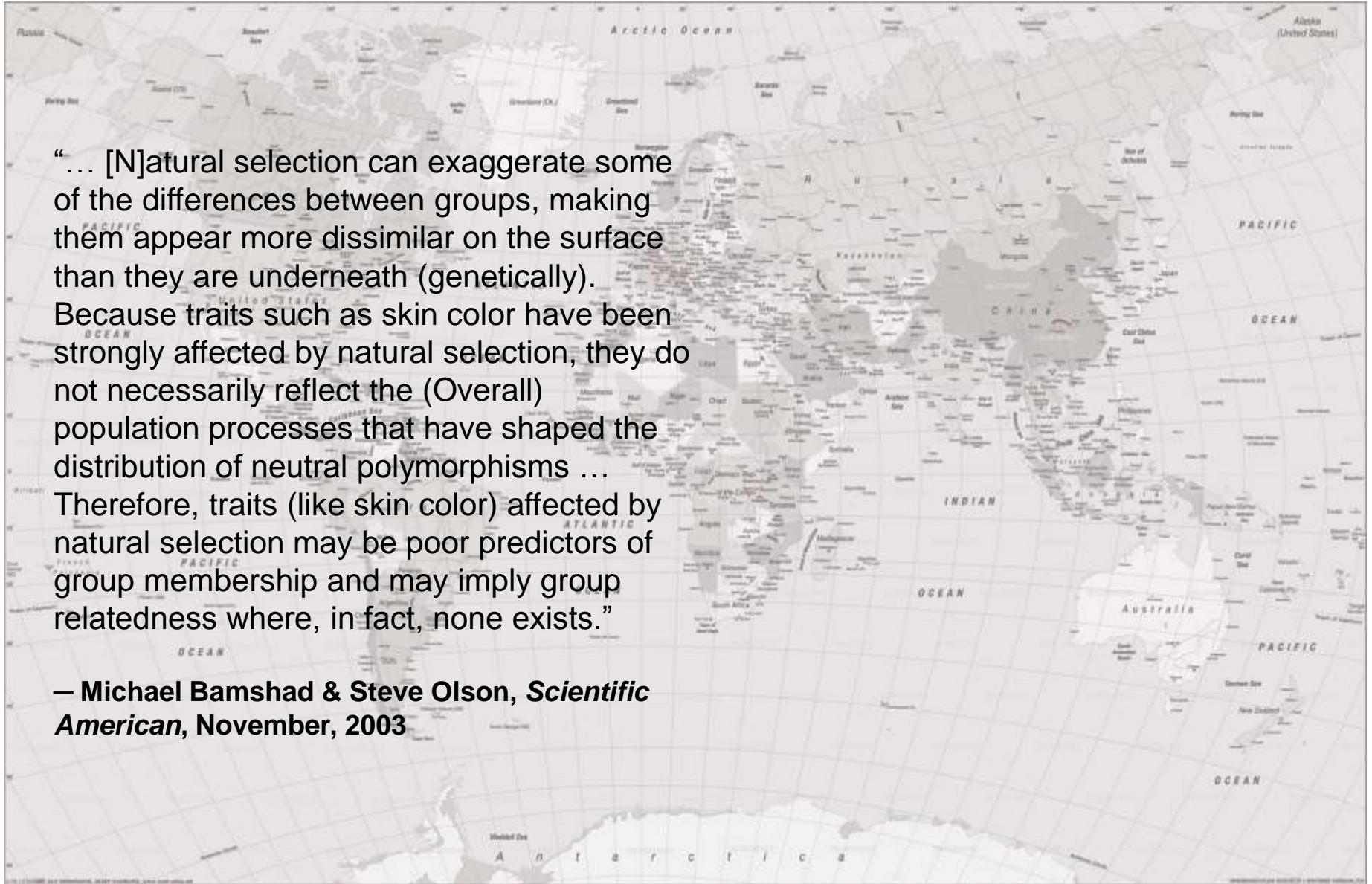

“... [N]atural selection can exaggerate some of the differences between groups, making them appear more dissimilar on the surface than they are underneath (genetically). Because traits such as skin color have been strongly affected by natural selection, they do not necessarily reflect the (Overall) population processes that have shaped the distribution of neutral polymorphisms ... Therefore, traits (like skin color) affected by natural selection may be poor predictors of group membership and may imply group relatedness where, in fact, none exists.”

— Michael Bamshad & Steve Olson, *Scientific American*, November, 2003

6

Race is not so much biological as it is a social construct, meaning it gives those of a certain distinction (whites in America for instance) advantages whether they are aware of it or not.



7

Colorblindness will not end racism. Pretending race does not exist is not the same as creating equality or correcting social policies that advantage one group over another.

<http://www.youtube.com/watch?v=V9YMCKp5myI> **Race - the Power of an Illusion I, 5 min**

<http://www.youtube.com/watch?v=4UZS8Wb4S5k> **Race - the Power of an Illusion II, 5 min**

<https://www.youtube.com/watch?v=f3JtV5VnU-s> **Chris Rock Explains Some of How Racism (White Supremacy) Works, 5:37 Min**

<https://www.youtube.com/watch?v=SzqEaiGR7Xo&list=PL3C2A795C6A8FCDA2> **The History of Racism - Episode 1 (part 1/6), 10 Min**

<https://www.youtube.com/watch?v=eKx9CcHZ28c&list=PL3C2A795C6A8FCDA2&index=2> **The History of Racism - Episode 1 (part 2/6), 10 Min**

http://www.youtube.com/watch?v=mW764dXEI_8 **Race, the House we Live In, 6 min**

<http://www.youtube.com/watch?v=TNVq3adFXGY> **A Question of Color, 4 min**

<http://www.youtube.com/watch?v=3FmEjDaWqA4> **Scientific Racism The Eugenics of Social Darwinism 360p, 1 hr**

Since there is no genetic variation that really distinguishes us, what pushes us to chose the variants we do and claim they are significant in a given socio-economic context? Why did we chose skin color and claim it was a significant genetic variant? Enough to justify slavery and many unethical injustices?
